

Triton Fabwall Bass™

Fabric Wrapped Low Frequency Sound Absorber Panel

Technical Data sheet—BPIR Class 2



asona



Description.

Triton Fabwall Bass™ is a sound absorbing fabric wrapped acoustic wall or ceiling panel designed to provide an attractive finish and control unwanted low frequency noise.

Application.

Triton Fabwall 50/100/150 Bass™ are designed for low frequency absorption.

Composition.

Manufactured in NZ from bio-soluble glass wool absorber with impact resistant Sonatex™ interlayer and wrapped in a range of decorative fabric finishes (polyester, wool, other).

Features & Benefits.

- High sound rating targeted for bass low frequency absorption.
- Provides a soft decorative finish to interiors.
- Rich palette of fabric finishes, textures and colours.
- Durable resilient composite construction for long life.
- Pre-fabricated for fast installation on site.
- Standard and custom sizes.
- Fire safe glass wool core, will not melt or burn like foam or polyester fibre panels.
- Fire Group 1-S (subject to fabric selection).
- Low VOC, GreenTag certified / Level A.

Technical Specifications

Sound Absorption Ratings: 'A' Mounting per ASTM C423, ISO 354, Test reports T0817-2, T0619-8, T0609-5

Panel	Hz	63	125	250	500	1000	2000	4000
50 Bass	αp	0.30	0.75	0.75	0.60	0.50	0.40	0.35
100 Bass	αp	0.25	0.90	0.75	0.45	0.25	0.20	0.30
150 Bass	αp	0.55	0.30	0.10	0.05	0.05	0.10	0.10



Triton Fabwall Bass™

Fabric Wrapped Low Frequency Sound Absorber Panel

Technical Data sheet—BPIR Class 2



asona

Sizes:

Absorber Thickness: 50, 100, 150 mm.
Panel Width: 100 to 1200 mm.
Panel Length: 100 to 3000mm mm.
Made to measure sizes available to order, consult Asona Ltd.

Fabric Finishes:

Screen and partition fabrics from polyester, wool, hemp/linen other fabrics available to request. Fabric selection may affect fire and acoustic performance. Client supplied fabric subject to prior approval, contact Asona.

Environmental impact:

Core from 80% recycled local glass waste. Product can be renewed. Low VOC. <0.05.

Maintenance:

Clean with vacuum, soft brush or damp cloth.

Limitations:

- For interior use only, and not in direct contact with water.
- Maximum humidity/temperature 90% R/H at 30°C.
- Panels with digital printed fabric must not butt together due to image creep formed during the printing process. If large panel images are required then use Snaptex™ stretch fabric system with wide format fabric.

NZ Building Act

This product is not subject to a warning or ban under Section 26.

NZ Building Code Compliance:

- B2 Durability – Clause B2.3.1 (c) (i): Asona Triton Fabwall Bass with only normal maintenance will have a minimum durability of at least 5 years when installed in accordance with manufacturer's installation requirements.
- C3 Fire – Clause C/AS2 3.4(a): Asona Triton Fabwall Bass with polyester fabric has a Fire Material Group Number 1-S by NZBC verification method C/VM2 Appendix A, tested in accordance with ISO 5660 or ISO 9705. (NCC BCA C1.10 clause 4, spec A2.4 clause 4. Group 1). BRANZ test report FI-14081. Other fabrics 2-S, 2 and 3. Please consult Asona.

Warranty:

15 year limited warranty against manufacturing defects.

Weight:

2.5—4.5 kg/m²

Tolerances:

+/-3 mm

Installation:

Triton Fabwall Bass™ panels are a finishing trade. Installation shall not commence until the building is water tight and all work such as plastering, concrete, masonry, carpentry, painting is complete and site free of dust and debris. Not for high impact prone areas, consult Asona for impact resistant acoustic panel options.

Mounting System:

Wall mounting non accessible —concealed impaling plates with adhesive fix, or semi concealed side impaling brackets. Wall mounting accessible— aluminium split rail and Z clips. Ceiling mounting—semi concealed side impaling brackets.

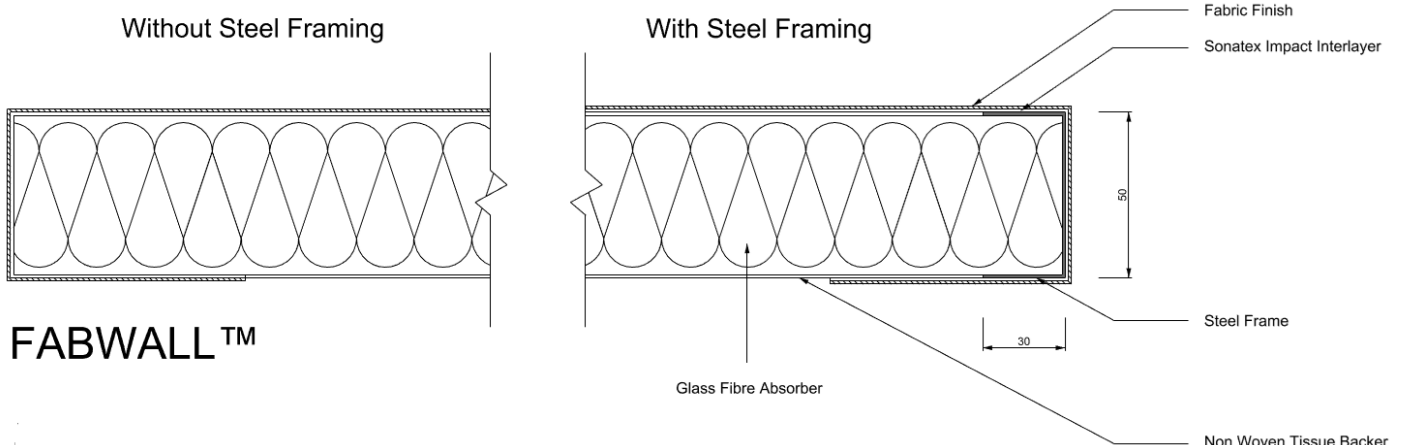

Specification:

Acoustic wall panels shall be Asona Triton Fabwall Bass™ fabric wrapped panels as manufactured by Asona Ltd Tel: 09 525 6575, email: info@asona.co.nz, module () x () mm, panel thickness (50)(100)(150)mm Bass) Fire Group 1-S (other). Selected fabric finish shall be (woven polyester) (other) and laminated to the face, all edges and a return on the back. Installed with (impaling plates and adhesive) (semi concealed side impaling brackets) (concealed split rail) by manufacturers approved fixer. Contractor shall flat pack packaging and return to Asona for reuse and register the panels with Asona Renew and Reuse product stewardship program on practical completion-NZ only. (Asona ceiling Masterspec 5172AA specification available).

Asona Ltd

Office and Factory:
Units 12-16, 7 Cain Road
Penrose, Auckland 1061,
New Zealand
T: +64(0)9 525 6575
E: info@asona.co.nz
W: www.asona.co.nz
NZBN: 9429036035175

Australia:

T: 1 800 240361
E: info@asona.com.au
W: www.asona.com.au

ISO 9001:2015 Registered Firm No. NZ1014

© 2024 Copyright ASONA Ltd Asona, Triton, Fabwall Bass, are trade marks of Asona Ltd.
*All dimensions are nominal. We reserve the right to change specifications.
Ref. Fabwall B -24.7

